

Plasma-Powder-Torch PTR450

Technical data according to EN 60 974-7

Rating:	400A DC
Duty cycle:	@100%
Tungsten:	5,0mm
Pilot current:	5 - 50A
Filler metal:	metal powder, carbid powder
Powder flow rate:	max. 80g/min
Cooling method:	2-circuit water cooling
Powder method:	2-Powder feeder

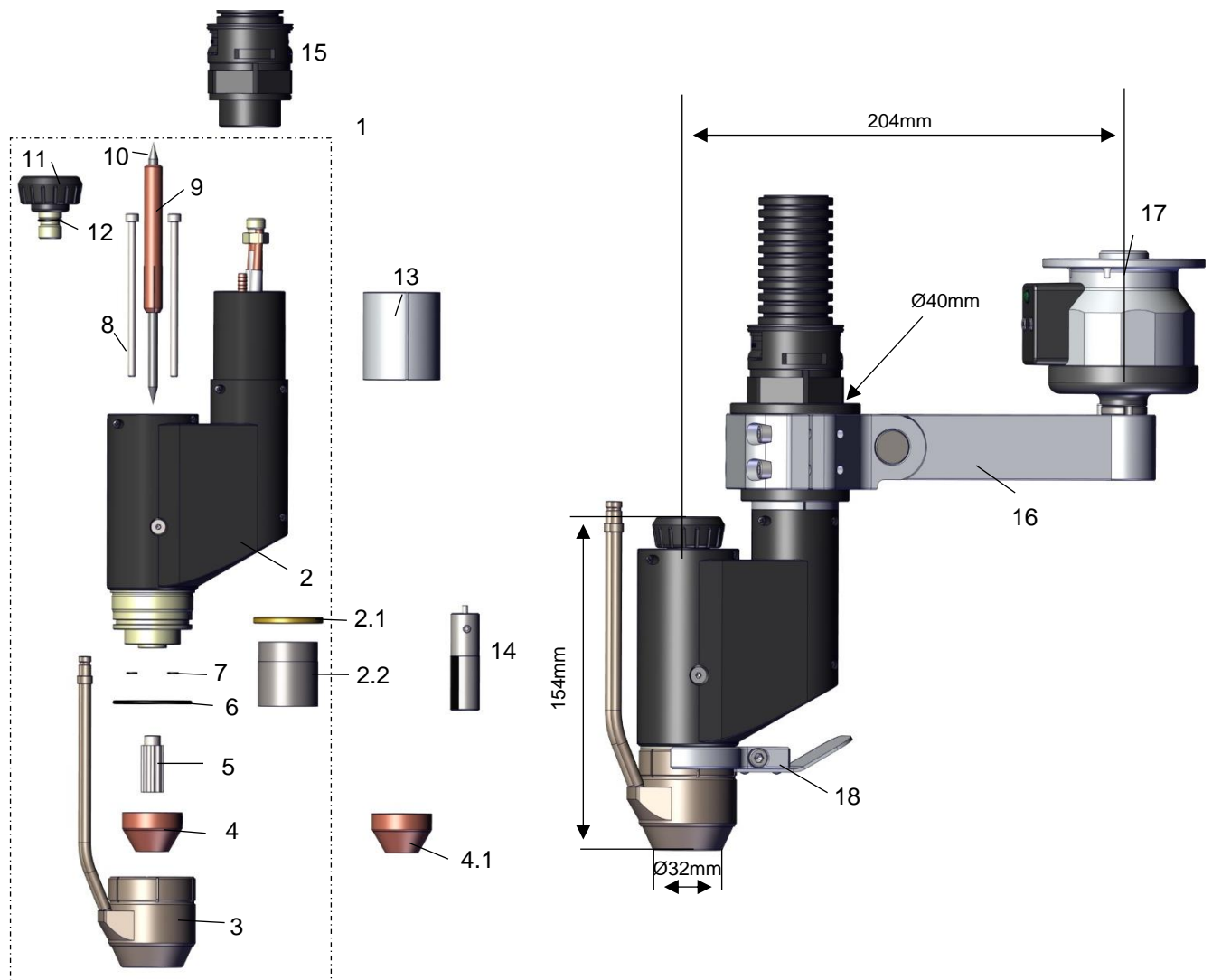





Part Number for complete Welding Torch

Part No.	4m
Plasma-Powder-Torch PTR450/4m	3545211XX

Spare Part List

Pos.	Part No.	Description	Pos.	Part No.	Description
1	354520010	Body Torch PTR450 cpl. (Pos. 2-12)	7	0041000	O-ring 4x1,0mm
2	354520011	Body Torch PTR450 (includet 2.1 & 2.2)	8	354520008	Screw for Anode PTR450
2.1	354520018	Ring for nozzle	9	354520004	Collet Ø5,0mm PTR450
2.2	3545200181	Insulation tube		3545200041	Collet Ø4,0mm PTR450
3	354520019	Gas nozzle watercooled	10	354520003	Tungsten electrode Ø5,0mm PTR450
4	354520101	Anode Ø3,6 – 4x1,8mm l=20mm		3545200031	Tungsten electrode Ø4,0mm PTR450
	354520104	Anode Ø3,0 – 4x1,8mm l=20mm	11	354520005	Torch cap PTR450
	354520105	Anode Ø2,8 – 4x1,8mm l=20mm	12	67329001	O-ring 10x1,5mm
	354520106	Anode Ø3,0 – 4x1,5mm l=20mm	13	354520051	Shell for mounting arm
	354520107	Anode Ø2,8 – 4x1,5mm l=20mm	14	354520007	Gauge PTR450
	354520108	Anode Ø3,0 – 4x1,2mm l=20mm	15	35004998	Tube connection M40x1-NW36
	354520109	Anode Ø2,8 – 4x1,2mm l=20mm	16	20042502	Holding fixture straight
4.1	354520102	Anode Ø3,0 – 2x1,5mm l=20mm	17	20040034	Robot Mount ARB-2 "medium" incl. signal cable and mounting kit
	354520103	Anode Ø3,5 – 2x1,5mm l=20mm		20040036	Robot Mount ARB-2 "medium-plus" incl. signal cable and mounting kit
	For any other dimensions, please contact us.			20040037	Robot Mount ARB-2 "max" incl. signal cable and mounting kit
			18	354520009	Heat shield PTR450
	Anode 4x Powder-holes (Pos. 4)	Anode 2x Powder-holes (Pos. 4.1)	no fig.	75105105	Silicon
5	354510460	Ceramic sleeve Ø5,0mm	no fig.	9940000174	Stater-kit for PTR450 consists of: 4x 0041000 O-ring 1x 354520004 Collet 2x 354520008 Screw 1x 354520003 Tungsten electrode 1x 354510460 Ceramic sleeve 2x 67329001 O-ring 1x 354520101 Anode 1x 354520007 Gauge 1x 75105105 Silicon
	354510462	Ceramic sleeve Ø4,0mm			
6	354520021	O-ring 36x2,0mm			