

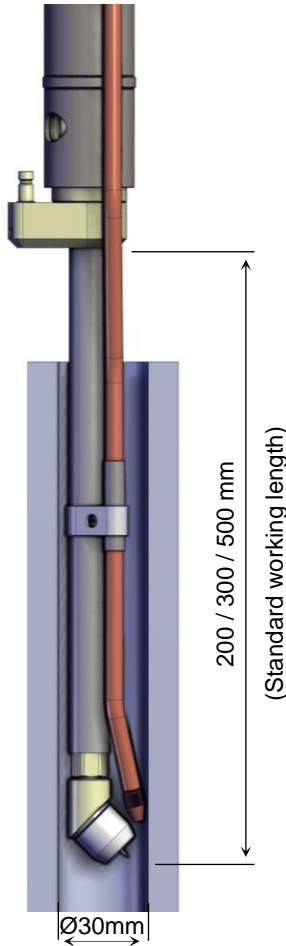

Information overview: Cladding Torch CLW 205 – Ø30mm



Special features:

- *Efficient torch system (CLW 205: 200A)*
- *100% Duty Cycle*
- *Water cooling system*
- *Torch head 30° - 90°*
- *Quick change torch head and torch neck*
- *Ready for hot wire*
- *Upgradable to CLW 250 (250A) and CLW 305 (300A)*

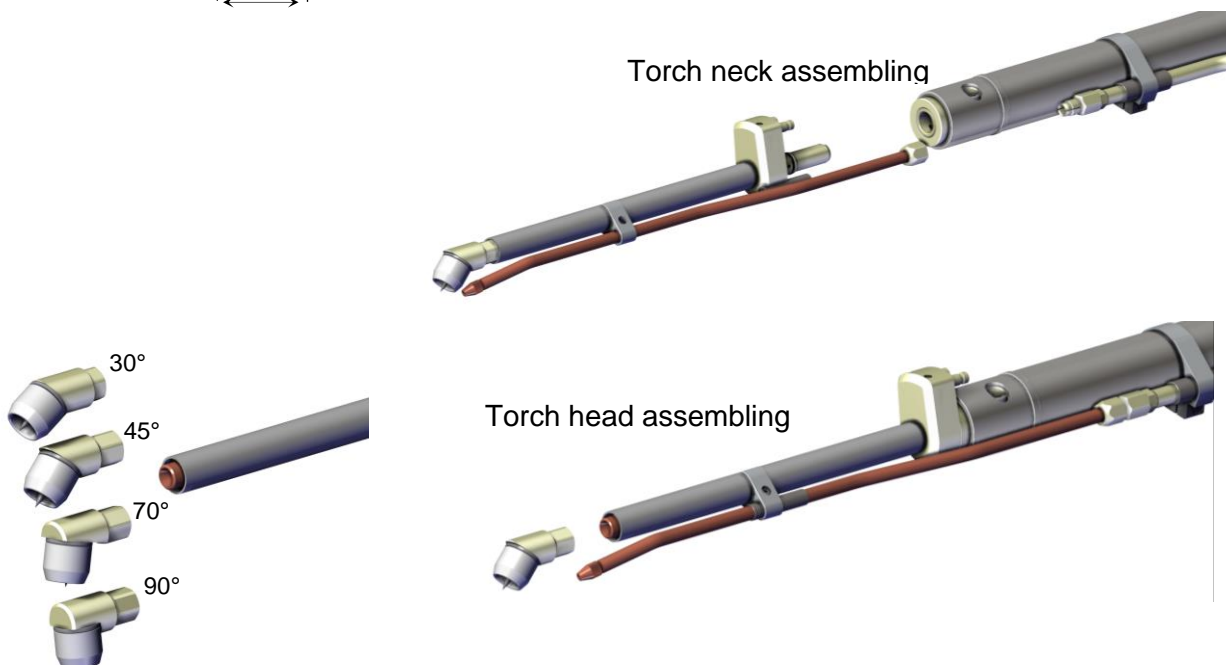

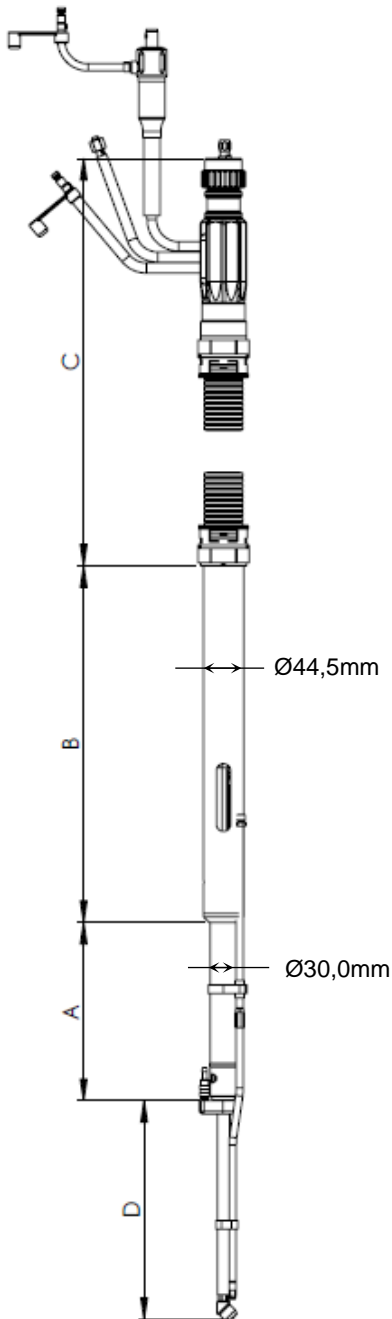

Technical Data CLW 205:

| | |
|--------------------------------|---|
| <i>Work piece-inside-Ø 205</i> | <i>30mm min (1 ¼ inch)</i> |
| <i>Welding current</i> | <i>max. 200A (100% ED)</i> |
| <i>Wire-Ø</i> | <i>0,8 / 1,0mm</i> |
| <i>Electrode-Ø</i> | <i>1,6 / 2,4mm</i> |
| <i>Flow rate cooling water</i> | <i>min. 2l/min</i> |
| <i>A</i> | <i>200mm</i> |
| <i>B</i> | <i>400mm</i> |
| <i>C</i> | <i>On request</i> |
| <i>D</i> | <i>200 / 300 / 500mm</i> |
| | <i>(Other lengths available on request)</i> |

- Cable assembly connections are made according to customer specifications
- Optionally available as hot or cold wire